



DuPont™ Flashing Tape

Cost-effective way to protect the jambs and heads of residential and multifamily windows from water intrusion.

- 4" x 33'
- 4" x 75'
- 6" x 75'
- 9" x 75'
- 12" x 75'

DuPont™ FlexWrap™

Seamless, no fastener protection of 3D window sills, and half round windows for residential and commercial construction.

- 6" x 75' (for 2x4 framing)
- 9" x 75' (for 2x6 framing)

DuPont™ StraightFlash™

Commercial flashing for straight heads and jambs of windows. Commonly used for transitions to steel, concrete, and other non-Tyvek® materials.

- 9' x 125' (1125 SF per roll)
- 10' x 125' (1250 SF per roll)

DuPont™ StraightFlash™ VF

Unique dual-sided, self-adhered flashing tape used for brick mould and non-flanged windows and doors for residential and commercial construction.

- 6" x 125'



DuPont™ FlexWrap™ EZ

Ideal flashing around small electrical, HVAC, and plumbing penetrations. An easy solution to help improve the durability of a wall system.

- 2 3/4" x 15' roll

DuPont™ Residential Sealant

A durable, highly flexible sealant for window and door installations and general construction applications.

- 10.3 ounce
- 20 ounce tubes
- 12 tubes per case



DuPont™ Tyvek® Wrap Caps

Used for fastening of DuPont™ Tyvek® roll goods whether for residential or commercial construction.

- Plastic cap 2" screw | length 1 3/4"
- 1000 screws per box
- Caps only at 2000 per box

DuPont™ RainVent™ Batten

Provides a ventilated rainscreen and drainage plane.

- 3/8" x 1 5/8" x 96"
- 40 pieces per case

DuPont™ Flashing Systems Benefits:

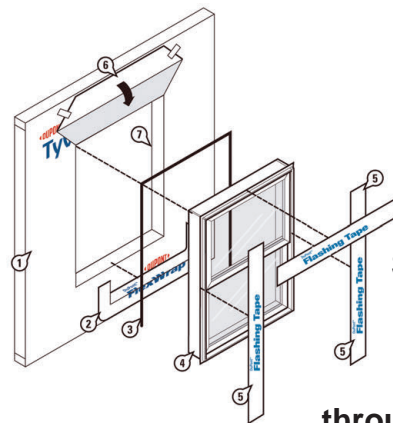

Easy installation

Quick release backing

Superior protection from water damage

Butyl adhesive performs through extreme temperature

Contains no asphalt

Designed for 120 days of UV exposure

Forgiving initial tack, easily repositioned

Adheres to most common building materials

Durable, tough, tear-resistant

Building Science-trained field support



distributed by Weatherization Partners, Ltd.