



DuPont™ Tyvek® Water-Resistive and Air Barriers Installation Guidelines

FOR OPEN STUD CONSTRUCTION



Tyvek®

**FOR BUILDINGS LESS THAN 5 STORIES AND LOW-RISE MULTI-FAMILY
RESIDENTIAL BUILDINGS LESS THAN 6 STORIES**

REVISION 5/18

Table of Contents

Applicable Products	3
Warranty	4
Water-Resistive Barrier (WRB) Code Requirements	4
General Instructions	5
Special Considerations	5
Installation Instructions.....	6
Continuity	7
Terminations	7
Gable Ends.....	7
Cantilever Floors	7
Installation of Metal Flashing at Façade Transitions.....	8
Penetrations	9
Method 1	9
Method 2	10
Method 1	11
Method 2	11
Method 1: Flashing Non-Flanged Products Using DuPont™ FlexWrap™ NF.....	12
Method 2: Flashing Non-Flanged Products Using DuPont™ FlexWrap™ EZ.....	13
Flashing Beam Penetrations.....	14
Handling Tears and Holes	15
DuPont Flashing Systems Integration	16
Facade Considerations	18
Stucco and Direct-Applied Stone.....	18
Brick	18
Stone Veneer	18
Wood Siding	18
Fiber Cement Siding	19
Vinyl Siding	19
EIFS	19
Exterior Insulation.....	19
Temporary Fastening.....	19
Key Installation Requirements for DuPont™ Tyvek® WRBs	20
Continuity	20
Penetrations.....	20
Fasteners.....	20
Proper Overlap for Water Management	21
Technical Specifications.....	22
Warning	22
Note	22

Applicable Products

Water-Resistive Barriers (WRB)

PRODUCT	DIMENSIONS	AREA
DuPont™ Tyvek® HomeWrap®	3 ft x 100 ft	300 sq ft
	3 ft x 165 ft	495 sq ft
	5 ft x 200 ft	1,000 sq ft
	9 ft x 100 ft	900 sq ft
	9 ft x 150 ft	1,350 sq ft
	10 ft x 100 ft	1,000 sq ft
	10 ft x 150 ft	1,500 sq ft
DuPont™ Tyvek® StuccoWrap®	5 ft x 200 ft	1,000 sq ft
DuPont™ Tyvek® DrainWrap™	9 ft x 125 ft	1,125 sq ft
	10 ft x 125 ft	1,250 sq ft
DuPont™ Tyvek® ThermaWrap™ LE	5 ft x 150 ft	750 sq ft
	9 ft x 100 ft	900 sq ft
DuPont™ Tyvek® CommercialWrap®	5 ft x 200 ft	1,000 sq ft
	10 ft x 125 ft	1,250 sq ft
DuPont™ Tyvek® CommercialWrap® D	5 ft x 200 ft	1,000 sq ft
	10 ft x 125 ft	1,250 sq ft

Flashing Products

PRODUCT	WIDTH
DuPont™ FlexWrap™ EZ	2.75 in
DuPont™ FlexWrap™ NF	6 in
	9 in
DuPont™ StraightFlash™	4 in
	9 in
DuPont™ StraightFlash™ VF	6 in
DuPont™ Flashing Tape	4 in
	6 in
	9 in
	12 in

DuPont™ Tyvek® Water-Resistive and Air Barriers Installation Guidelines for Open Stud Construction

Installation Accessories

PRODUCT	TYPE	QUANTITY
DuPont™ Tyvek® Tape	2" Bulk Pack 3" Bulk Pack	36 rolls/case 24 rolls/case
DuPont™ Tyvek® Metallized Tape	2" x 100' Rolls	12 rolls/case
DuPont™ Tyvek® Wrap Cap staples or other cap staples for Stinger™ Cap Stapler	7/8", 1-1/4", and 1-1/2" lengths 3/8" and 5/8" lengths	2,000/box 2,016/box
DuPont™ Tyvek® Wrap Cap nails	1" electro-galvanized ring shank nail	2,000/box
DuPont™ Tyvek® Wrap Cap screws	2" dia. plastic cap, 1-3/4" screw length	1,000/box
DuPont™ Adhesive/Primer		
DuPont™ Window and Door Foam		
DuPont™ Residential Sealant		
DuPont™ RainVent™ Battens	5/8 in x 3/8 in x 8 ft	40/pack

Warranty

Please refer to the *DuPont Weatherization Products 10-Year Limited Warranty for Buildings Less Than 5 Stories and Low-Rise Multi-Family Buildings Less Than 6 Stories*. For buildings greater than 4 stories, please refer to the *DuPont Weatherization Products 10-Year Limited Warranty for Buildings Greater Than 4 Stories*.

Water-Resistive Barrier (WRB) Code Requirements

The 2015 International Residential Code (Section R703.1.1 Water Resistance) requires that "the exterior wall envelope shall be designed and constructed in a manner that prevents the accumulation of water within the wall assembly by providing a water-resistant barrier behind the exterior veneer as required by Section R703.2 and a means of draining to the exterior water that enters the assembly." Section R703.2 (Water-resistive barrier) states that "one layer of No. 15 asphalt felt, free from holes and breaks, complying with ASTM D 226 for Type 1 felt or other approved water-resistive barrier shall be applied over studs or sheathing of all exterior walls. Such felt or material shall be applied horizontally, with the upper layer lapped over the lower layer not less than 2 inches (51 mm). Where joints occur, felt shall be lapped not less than 6 inches (152 mm). The felt or other approved material shall be continuous to the top of walls and terminated at penetrations and building appendages in a manner to meet the requirements of the exterior wall envelope as described in Section R703.1."

The 2015 International Building Code (Section 1403.2 Weather Protection) requires that "exterior walls shall provide the building with a weather resistant exterior wall envelope. The exterior wall envelope shall include flashing, as described in Section 1405.4. The exterior wall envelope shall be designed and constructed in such a manner as to prevent the accumulation of water within the wall assembly by providing a water-resistive barrier behind the exterior veneer, as described in Section 1404.2, and a means for draining water that enters the assembly to the exterior. Section 1404.2 (Water-resistive barrier) states that "not fewer than one layer of No. 15 asphalt felt, complying with ASTM D 226 for Type 1 felt or other approved materials, shall be attached to the studs or sheathing, with flashing as described in Section 1405.4, in such a manner as to provide a continuous water-resistive barrier behind the exterior veneer.

The DuPont™ Tyvek® WRBs listed below qualify as approved water-resistive barriers based on ICC-ES AC308 Acceptance Criteria according to the associated Evaluation Reports

- ICC-ES Evaluation Report ESR 2375
 - DuPont™ Tyvek® HomeWrap®
 - DuPont™ Tyvek® StuccoWrap®
 - DuPont™ Tyvek® DrainWrap™
 - DuPont™ Tyvek® CommercialWrap®
 - DuPont™ Tyvek® CommercialWrap® D
- ICC-ESR-1993: DuPont™ Tyvek® ThermaWrap™ LE

And Industry Standard ASTM E 2556 Type II Standard Specification for Vapor Permeable Flexible Sheet Water-Resistive Barriers Intended for Mechanical Attachment

Air leakage control and air barriers are required in the IECC-2015 Sections R402.4 and C402.4. Specifically, Section C402.5 identifies three compliance options for air barriers. DuPont™ Tyvek® WRBs comply with the option detailed in Section C402.5.1.2.1: "C402.5.1.2.1 Materials. Materials with an air permeability no greater than 0.004 cfm/ft² (0.02 L/s x m²) under a pressure differential of 0.3 inches water gauge (75 Pa) when tested in accordance with ASTM E 2178 shall comply with this section." Tyvek® WRBs have been tested in accordance with ASTM E2178 and have air permeability less than 0.02 L/s x m².

DuPont™ Tyvek® Water-Resistive and Air Barriers Installation Guidelines for Open Stud Construction

DuPont™ Tyvek® WRBs have been tested to the following standards:

- ASTM E 1677 Standard Specification for an Air Retarder (AR) Material or System for Low-Rise Framed Building Walls
- ASTM E 2178 Standard Test Method for Air Permeance of Building Materials
- ASTM E96-05 Water Vapor Transmission
- AATCC 127 Water Penetration Resistance
- ASTM E 84 Standard Test Method for Surface Burning Characteristics of Building Materials

The application of DuPont™ Tyvek® WRBs is governed by the code adopted and enforced by the local jurisdiction. Consult your jurisdiction to assure compliance with the local building code.

General Instructions

The best time to install DuPont™ Tyvek® water-resistive barriers is:

- **AFTER** the roof sheathing is installed
- **AFTER** the step flashings and kickout flashings have been installed
- **BEFORE** any new windows and doors are installed.

DuPont™ Self-Adhered Flashing products are not intended for through-wall flashing applications.

Special Considerations

1. Wall assemblies using equivalent fasteners must meet or exceed ASTM E1677 performance requirements of 65 mph equivalent structural load resistance and 15 mph equivalent wind-driven rain water infiltration resistance.
2. When performance requirements exceed ASTM E1677, 65 mph equivalent structural load and 15 mph equivalent wind-driven rain water infiltration for buildings less than 5 stories, it is recommended to install a high pressure skirt to help prevent water intrusion at the sill or threshold and follow the *DuPont™ Tyvek® Mechanically Fastened Air and Water Barrier Installation Guidelines For Buildings Greater Than 4 Stories and High Performance Installations of Any Height and the DuPont Self-Adhered Self-Adhered Flashing Systems Installation Guidelines For Buildings Greater Than 4 Stories and High Performance Installations of Any Height.*
3. DuPont™ Tyvek® StuccoWrap™ and DuPont™ Tyvek® DrainWrap™ must be installed with drainage grooves vertical, going up and down. No surface preparation is needed for the installation of DuPont™ Tyvek® WRBs.

4. DuPont™ Tyvek® ThermaWrap™ LE must be installed with shiny, metallic side facing towards a clear ¾ inch minimum air space to obtain the installed R-Value benefits. ThermaWrap™ LE will still act as a water-resistive barrier without an airspace. Refer to the DuPont™ Tyvek® ThermaWrap™ LE Fact Sheet for more information.
5. DuPont requires that DuPont™ Tyvek® HomeWrap®, DuPont™ Tyvek® StuccoWrap®, DuPont™ Tyvek® DrainWrap™ and DuPont™ Tyvek® ThermaWrap™ LE be covered within 4 months (120 days) of installation. DuPont™ Tyvek® CommercialWrap® and DuPont™ Tyvek® CommercialWrap® D must be covered within 9 months (270 days) of installation.
6. DuPont requires that DuPont™ FlexWrap™ EZ, FlexWrap™ NF, StraightFlash™ and StraightFlash™ VF be covered within nine months (270 days) of installation. DuPont requires that DuPont™ Flashing Tape be covered within four months (120 days) of installation.
7. DuPont™ Self-Adhered Flashing products perform best when installed at temperatures above 25°F (–4°C).
8. DuPont™ Self-Adhered Flashing products should be installed on clean, dry surfaces that are free of frost. Wipe surfaces to remove moisture, dirt, grease and other debris that could interfere with adhesion.
9. Adverse weather conditions or cold temperatures may require use of a primer to promote adhesion of DuPont™ Self-Adhered Flashing products to most common building materials.
10. Concrete, masonry, and fiber-faced exterior gypsum board require the use of a compatible adhesive or primer.
11. Remove all wrinkles and bubbles that may allow for water intrusion by smoothing surface and repositioning as necessary during installation of DuPont™ Self-Adhered Flashing products. Apply pressure along entire surface of flashing for a good bond using firm hand pressure, J-roller, or alternate tool without sharp edges (such as a plastic carpet tuck tool) to assist with application of uniform pressure.

When installing windows and doors prior to the DuPont™ Tyvek® WRB, refer to the *DuPont™ Self-Adhered Flashing Systems Installation Guidelines, Installation Instructions for Windows and Doors BEFORE Water-Resistive Barrier (WRB) is Installed*, which will direct you back to this guide at the appropriate step.

If the windows and doors have already been installed and flashed, **integrate the DuPont™ Tyvek® WRB by following the DuPont Flashing Systems Integration section in this guide.**

NOTE: If DuPont™ FlexWrap™ NF and apron are used, install the DuPont™ Tyvek® WRB under the apron to ensure proper shingling. If a non-self adhering sill flashing product is used, please maintain proper shingling.

DuPont™ Tyvek® Water-Resistive and Air Barriers Installation Guidelines for Open Stud Construction

Installation Instructions

Start at bottom corner of structure to ensure proper shingling throughout the installation. Proper shingling is required to shed water and to prevent water from entering the wall system. Printed stud marks are available on some DuPont™ Tyvek® WRBs to aid in aligning with the studs (e.g. studmarks are 8" apart for DuPont™ Tyvek® HomeWrap®).

STEP 1

Align roll at bottom corner of structure. Roll should be plumb. Bottom edge of roll must:

- Extend over sill plate interface by at least 1" (2" or greater is recommended)
- Extend to bottom of sill plate for slab on grade foundations, OR,
- Be properly integrated with water drainage components such as kick out flashing or weep screed (for stucco exteriors).

When bottom edge of roll is less than 2" over the sill plate interface, it is recommended to seal or skip-seal the DuPont™ Tyvek® WRB at the bottom of the wall.*

NOTE: When using DuPont™ Tyvek® ThermaWrap™ LE under traditional and 1-coat stucco exteriors install silver side facing towards studs.

STEP 2

UNWRAP roll starting at corner. Overlap all vertical seams by 6-12".

STEP 3

Secure DuPont™ Tyvek® WRB to the stud or other nail-base material, i.e., wood sheathing. Fasteners should be placed no closer than 6" and no farther than 18" on vertical stud lines. Securing along stud lines will assist in maintaining fastening pattern. Penetrating bandboard or other horizontal members may be necessary to maintain fastening pattern. Do not install fasteners within 6" of the sills and jambs and within 9" of the head of the window rough openings. Use one or more of the recommended fasteners below for use with DuPont™ Tyvek® WRBs:

- DuPont™ Tyvek® Wrap Cap nails
- DuPont™ Tyvek® Wrap Cap screws
- DuPont™ Tyvek® Wrap Cap staples or other cap staples for Stinger™ Cap Stapler**

Other manufacturers' equivalent fasteners.

Please see "Special Considerations" section above for equivalent fastener requirements and "Temporary Fastening" section below for more information on alternative fastening schedules and requirements.

STEP 4

Unroll directly over windows and doors. Upper layer of DuPont™ Tyvek® WRB should overlap bottom layer of DuPont™ Tyvek® WRB by a minimum of 6".

Refer to the DuPont Self-Adhered Flashing Systems Installation Guidelines to prepare and flash window and door openings.

NOTE: If windows are already installed, the DuPont™ Tyvek® WRB must be integrated with window flashing using proper shingling. If DuPont™ FlexWrap™ NF and apron are used according to the *DuPont™ Self-Adhered Flashing Systems Installation Guidelines, Installation Instructions for Windows and Doors BEFORE Water-Resistive Barrier (WRB) is Installed*, install the DuPont™ Tyvek® WRB under the apron to ensure proper shingling. If non-self adhering sill flashing is used, install the DuPont™ Tyvek® WRB under the bottom of the sill flashing to maintain proper shingling. In either case, follow the DuPont Flashing Systems Integration steps of this guide to tie the DuPont™ Tyvek® WRB into the flashing.

STEP 5

Tape all vertical seams with DuPont™ Tyvek® Tape. If the DuPont™ Tyvek® WRB is not being installed as an air barrier, DuPont™ Tyvek® Tape is not required on horizontal seams but is considered a recommended best practice. Use 3" DuPont™ Tyvek® Tape for the horizontal seams of DuPont™ Tyvek® StuccoWrap® and DuPont™ Tyvek® DrainWrap™. Use DuPont™ Tyvek® Metalized Tape when taping DuPont™ Tyvek® ThermaWrap™ LE.

STEP 6 (For Air Barrier Installations)

When installing as an air barrier, the horizontal seams must be taped. The use of 3" DuPont™ Tyvek® Tape is required for both vertical and horizontal seams of DuPont™ Tyvek® StuccoWrap® and DuPont™ Tyvek® DrainWrap™ for air barrier installations.

STEP 7 (For Air Barrier Installations)

Taping or sealing all terminations of DuPont™ Tyvek® WRBs (including, but not limited to, roof-wall and bottom of the wall interfaces) using DuPont™ Tyvek® Tape, DuPont™ Residential Sealant (or recommended sealant), DuPont™ StraightFlash™, or DuPont™ Flashing Tape is required when installing as an air barrier.*

STEP 8

If windows and doors have not been installed, refer to the *DuPont™ Self-Adhered Flashing Systems Installation Guidelines, Installation Instructions for Windows and Doors AFTER Water-Resistive Barrier (WRB) is Installed* to prepare the rough opening.

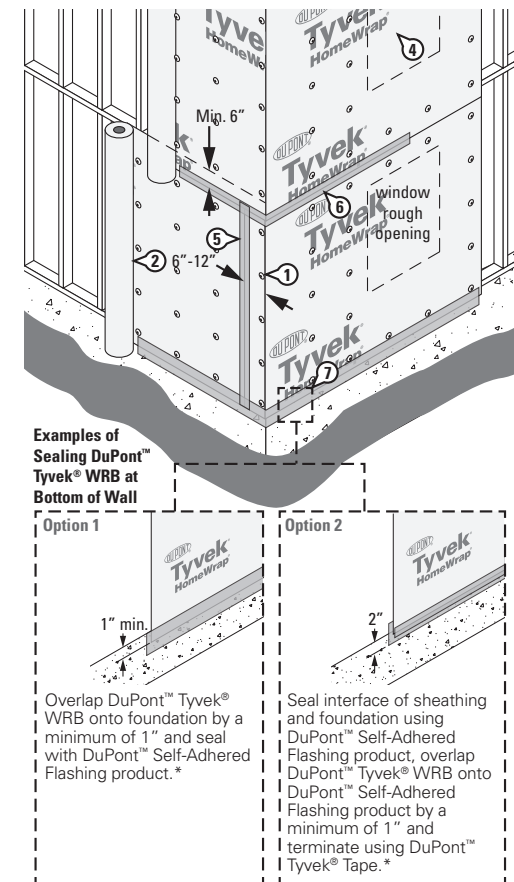

*Use DuPont™ Self-Adhered Flashing products with DuPont™ Adhesive/Primer (or recommended primer) as applicable to seal the DuPont™ Tyvek® WRB directly to concrete, wood, or other rough surfaces. The DuPont™ Tyvek® WRB can also be sealed to rough surfaces using DuPont™ Residential Sealant (or recommended sealant).

**Except when installing DuPont™ Tyvek® WRB over foam and other non-nail-base sheathings.

Continuity

It is important to maintain the continuity of the DuPont™ Tyvek® WRB from bottom to top with proper shingling. Starting from the bottom of the structure, continue wrapping all the way up, overlapping the previous layer of DuPont™ Tyvek® WRB by a minimum of 6". Wrap the entire wall surface including unconditioned spaces.

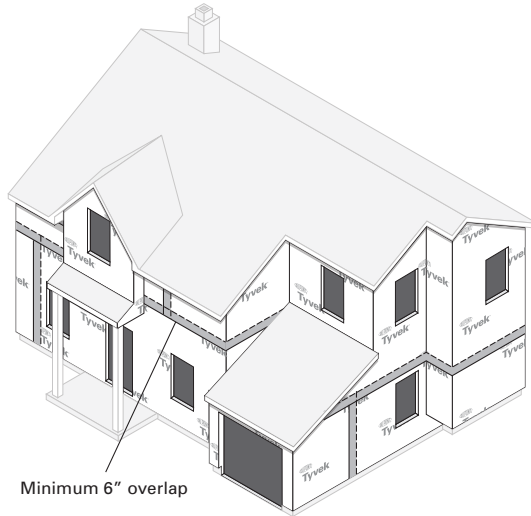

Terminations

Lap DuPont™ Tyvek® WRB over all flashing (e.g. step flashing, wall to roof intersections and through wall flashings).

Weep screeds and expansion joints need to be integrated with flashings and the DuPont™ Tyvek® WRB.

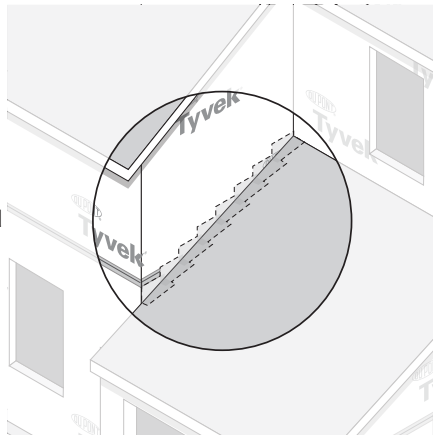

Gable Ends

Completely cover the Gable End with the DuPont™ Tyvek® WRB including a 6"-12" overlap at each corner. Cut away the excess WRB and tape all seams.

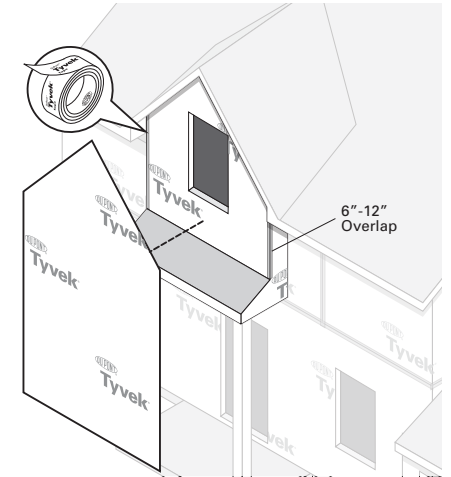

Cantilever Floors

Wrap the DuPont™ Tyvek® WRB under and up the Cantilever floor and fold the DuPont™ Tyvek® WRB up the sides of the Cantilever wall a minimum of 6". Tape all corners. The top layer of DuPont™ Tyvek® WRB should go over the bottom layer a minimum of 6".

NOTE: Make the inside corner as tight as possible using a 1x4 or similar.

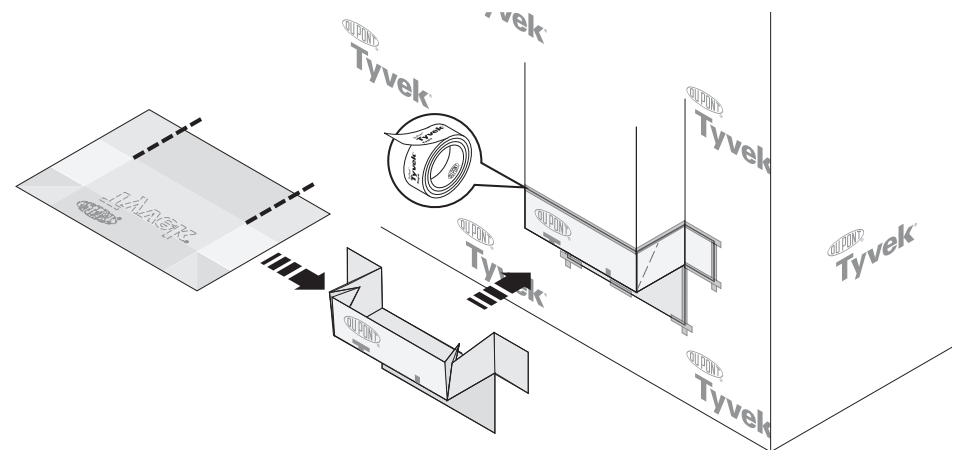

Installation of Metal Flashing at Façade Transitions

Option 1: Metal Flashing Terminated onto DuPont™ Tyvek® WRB

STEP 1

Install the “Z” or “L” metal flashing over the lower façade and onto the DuPont™ Tyvek® WRB with mechanical fasteners or DuPont™ Adhesive/Primer.

NOTE: Do not install DuPont™ Tyvek® WRB fasteners where the metal flashing or DuPont™ Self-Adhered Flashing products will be installed.

STEP 2

Terminate the vertical leg of the metal flashing to DuPont™ Tyvek® WRB with DuPont™ Self-Adhered Flashing product so there is a minimum of 2” adhesion onto the DuPont™ Tyvek® WRB.

STEP 3

Install the upper façade according to the manufacturer’s instructions.

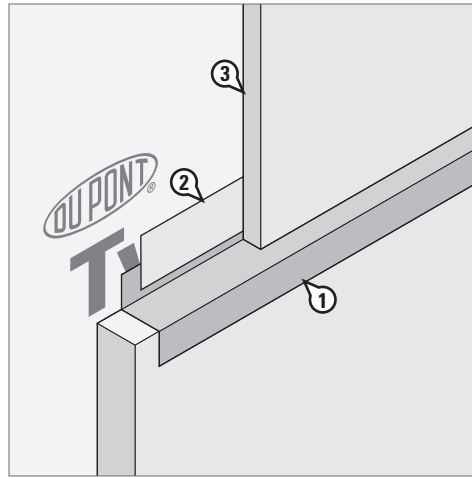

Option 2: Metal Flashing Terminated onto Sheathing

STEP 1

Install the first course of DuPont™ Tyvek® WRB so it extends a minimum of 2” beyond where the top edge of the lower façade will be located.

NOTE: Do not install DuPont™ Tyvek® WRB fasteners where the metal flashing or DuPont™ Self-Adhered Flashing products will be installed.

STEP 2

Install the “Z” or “L” metal flashing along the top edge of the lower façade with the vertical leg overlapping the DuPont™ Tyvek® WRB.

STEP 3

Terminate the vertical leg of the metal flashing directly to the sheathing with DuPont™ Self-Adhered Flashing product with minimum of 2” adhesion onto the sheathing.

STEP 4

Install the next course of DuPont™ Tyvek® WRB to overlap the DuPont™ Self-Adhered Flashing products by a minimum of 2” and seal with DuPont™ Tyvek® Tape or DuPont™ Residential Sealant.

STEP 5

Install upper façade according to the manufacturer’s instructions.

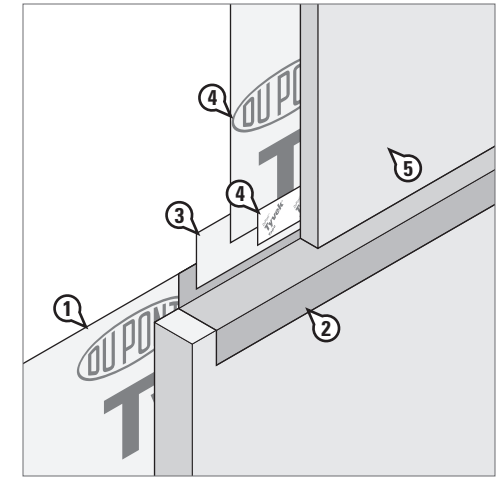

Penetrations

Seal around plumbing pipes, HVAC components, electrical outlets, exterior lights, flashing panels, and other objects that penetrate the DuPont™ Tyvek® WRB. Always use positive shingling by installing DuPont™ Tyvek® WRBs and Self-Adhered Flashing products from bottom to top, with upper layer installed over lower layer. **NOTE:** A backing support for flashing made of solid OSB or wood sheathing must be installed around the penetration before the DuPont™ Tyvek® WRB and flashing for open stud applications.

OPTIONAL LAST STEP FOR ALL INSTALLATIONS: Install a piece of DuPont™ Tyvek® WRB and seal with DuPont™ Tyvek® Tape to overlap the top edge of the DuPont™ Self-Adhered Flashing product (shown in Method 1 below).

Flashing Integral Flanged Products Installed AFTER DuPont™ Tyvek™ WRB

Method 1

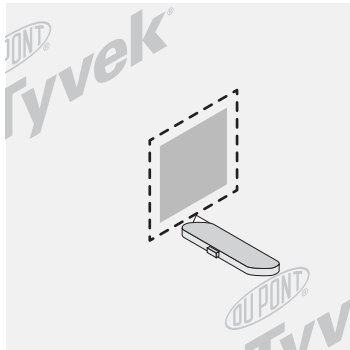

STEP 1

Install DuPont™ Tyvek® WRB and cut as necessary to accommodate integral flanged product.



STEP 2

Install integral flanged product per manufacturer's instructions.

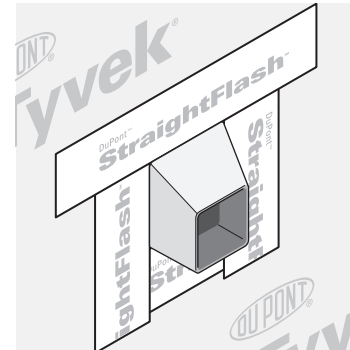

STEP 3

Install DuPont™ Self-Adhered Flashing onto sides and top flange, extending onto DuPont™ Tyvek® WRB by a minimum of 2". **NOTE:** Also install at bottom flange as a recommended best practice and for air barrier installations.

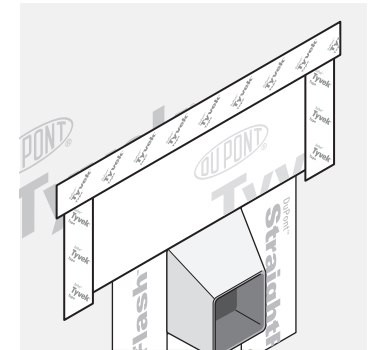

STEP 4 (OPTIONAL)

Install a piece of DuPont™ Tyvek® WRB to overlap the top edge of the DuPont™ Self-Adhered Flashing. Seal sides and top with DuPont™ Tyvek® Tape.

Flashing Integral Flanged Products Installed AFTER DuPont™ Tyvek™ WRB

Method 2

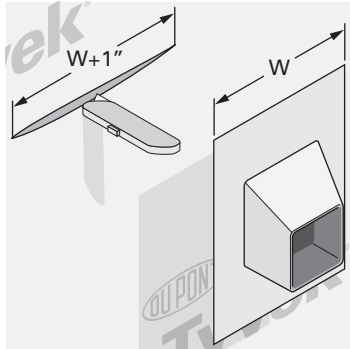

STEP 1

Install DuPont™ Tyvek® WRB and make horizontal cut a minimum of 1" wider than flange.

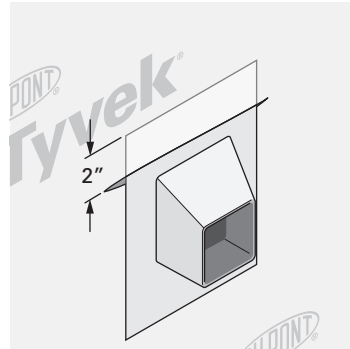

STEP 2

Slide top flange into slit with minimum 2" overlap of DuPont™ Tyvek® WRB, and install per manufacturer's instructions.

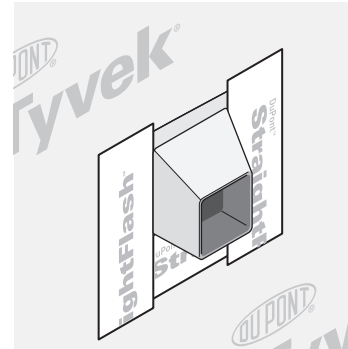

STEP 3

Adhere DuPont™ Self-Adhered Flashing onto side flanges, extending onto DuPont™ Tyvek® WRB by 2". **NOTE:** Also install at bottom flange as a recommended best practice and for air barrier installations.

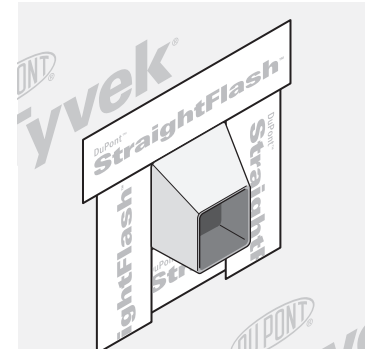

STEP 4

Install DuPont™ Self-Adhered Flashing to top flange, extending beyond DuPont™ Self-Adhered Flashing on side flanges.

DuPont™ Tyvek® Water-Resistive and Air Barriers Installation Guidelines for Open Stud Construction

Flashing Integral Flanged Products - Installed BEFORE DuPont™ Tyvek™ WRB

Method 1

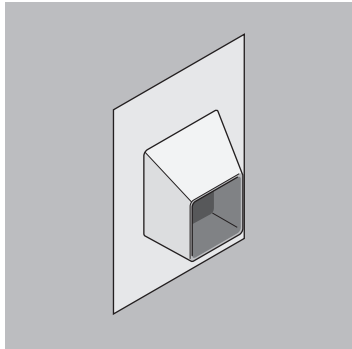

STEP 1

Install integral flanged product onto sheathing per manufacturer's instructions.

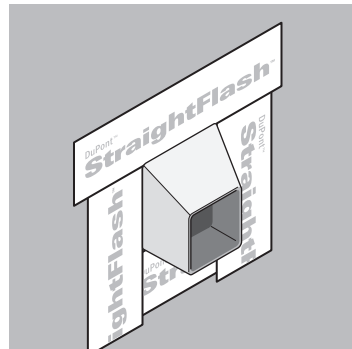

STEP 2

Install DuPont™ Self-Adhered Flashing onto flanges, extending onto sheathing by a minimum of 2".



STEP 3

Install DuPont™ Tyvek® WRB.

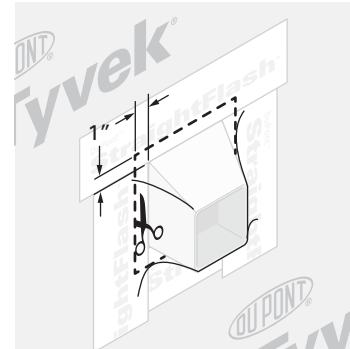

STEP 4

Make cut in DuPont™ Tyvek® WRB, ensuring a minimum of 1" gap for adhesion of DuPont™ Tyvek® Tape.



STEP 5

Seal edges of DuPont™ Tyvek® WRB with DuPont™ Tyvek® Tape.

Method 2

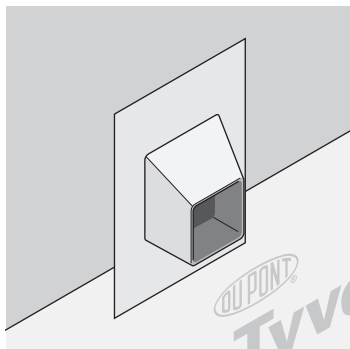

STEP 1

Install DuPont™ Tyvek® WRB under bottom flange.

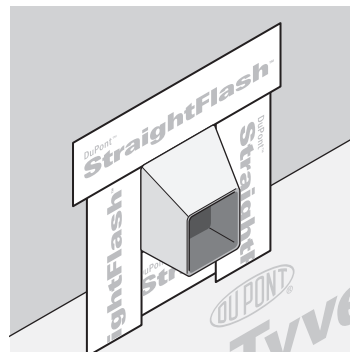

STEP 2

Adhere DuPont™ Self-Adhered Flashing onto sides and top flange. **NOTE:** Also install at bottom flange as a recommended best practice and for air barrier installations.

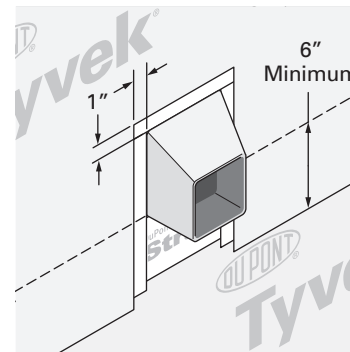

STEP 3

Install next course of DuPont™ Tyvek® WRB with a minimum of 6" overlap. Cut back 1" to expose flanges.

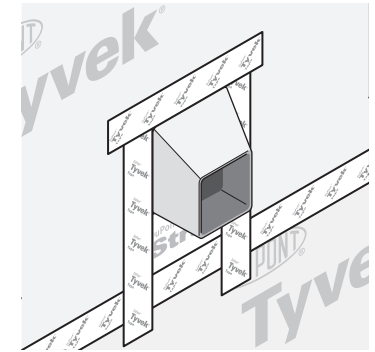

STEP 4

Seal seams using DuPont™ Tyvek® Tape.

Flashing Non-Flanged Products - Installed AFTER DuPont™ Tyvek™ WRB

Method 1: Flashing Non-Flanged Products Using DuPont™ FlexWrap™ EZ

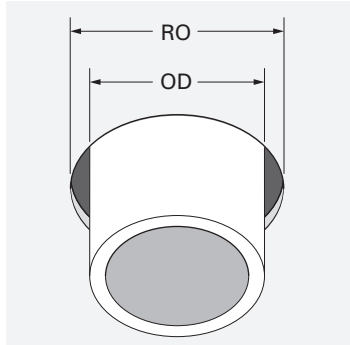

Use DuPont™ FlexWrap™ EZ only when penetration rough opening (RO) is not more than 1/2" larger than the outside diameter/dimension (OD) of non-flanged product.

For non-flanged products with OD GREATER than 2"



STEP 1

Install DuPont™ Tyvek® WRB over non-flanged product and cut around penetration.

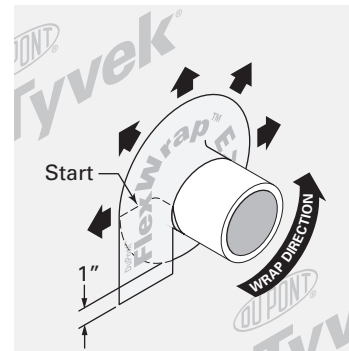

STEP 2

Cut a piece of DuPont™ FlexWrap™ EZ longer than the circumference of non-flanged product to ensure a minimum 1" overlap onto the DuPont™ Tyvek® WRB. Starting at the horizontal position on either side, adhere around penetration and onto DuPont™ Tyvek® WRB.

For non-flanged products with OD LESS than 2"



STEP 1

Install DuPont™ Tyvek® WRB over non-flanged product and cut around penetration.

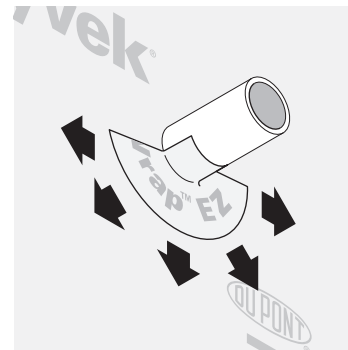

STEP 2

Cut a piece of DuPont™ FlexWrap™ EZ the length of 1/2 the circumference of the non-flanged product. Adhere onto bottom section and fan out onto DuPont™ Tyvek® WRB.

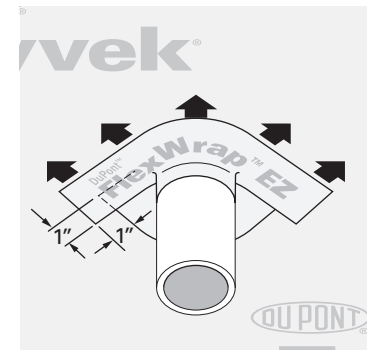

STEP 3

Cut a second piece of DuPont™ FlexWrap™ EZ the length of the pipe circumference. Adhere onto top section and fan out onto face of wall with a minimum of 1" overlap of the edges of DuPont™ FlexWrap™ EZ below.

Method 2: Flashing Non-Flanged Products Using DuPont™ FlexWrap™ NF

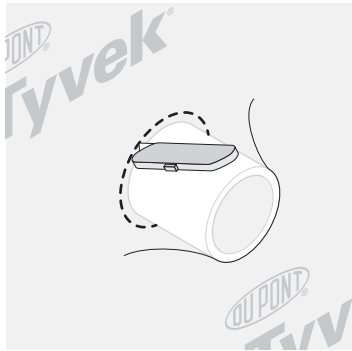

STEP 1

Install DuPont™ Tyvek® WRB over non-flanged product and cut around penetration.

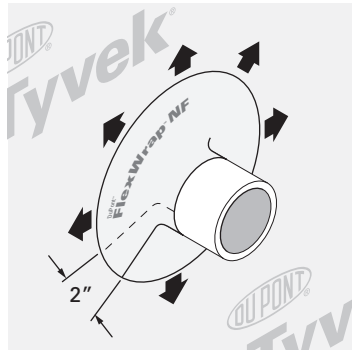

STEP 2

Starting at the horizontal position on either side, install DuPont™ FlexWrap™ NF around penetration with a minimum 2" overlap.

Flashing Beam Penetrations

NOTE: A backing support for flashing made of solid OSB or wood sheathing must be installed around the beam before the DuPont™ Tyvek® WRB and flashing for open stud applications.

STEP 1

- A. Install the first course of DuPont™ Tyvek® WRB so the top edge is flush with the bottom of the beam.

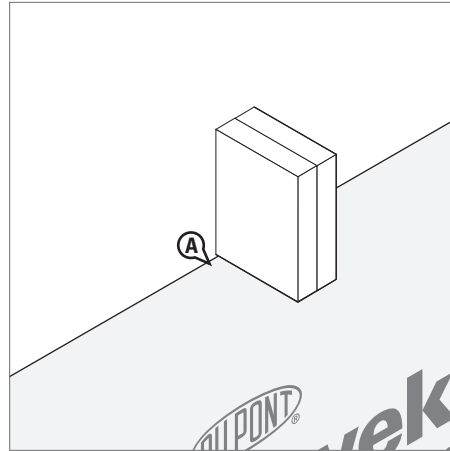

STEP 2

- A. Cut pieces of DuPont™ Tyvek® WRB to fit between beams. The pieces should extend a minimum of 7" above the beams and overlap the course below by a minimum of 6". Seal the vertical seams with DuPont™ Tyvek® Tape.

NOTE: For air barrier installations, seal all vertical and horizontal seams.

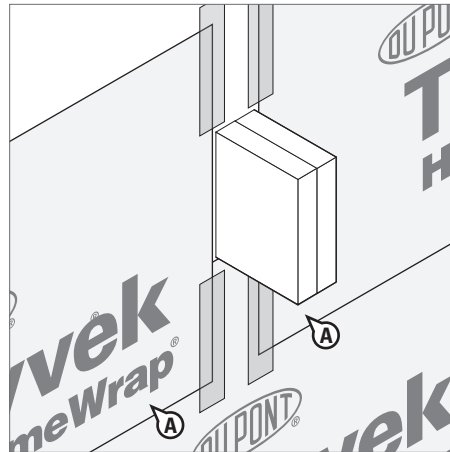

STEP 3

Seal around the beam using two pieces of 6" wide DuPont™ FlexWrap™ NF.

- A. Cut the first piece of DuPont™ FlexWrap™ NF long enough wrap around the bottom half of the beam. Break the perforation in the release paper by folding the DuPont™ FlexWrap™ NF top sheet to the inside of the fold. With the DuPont™ FlexWrap™ NF still folded, remove the narrow piece of release paper and adhere the exposed butyl to the bottom and up each side of the beam. Remove the remaining release paper and fan the DuPont™ FlexWrap™ NF out onto the DuPont™ Tyvek® on the face of the wall.
- B. Cut the second piece of DuPont™ FlexWrap™ NF long enough to wrap around the top half of the beam, overlapping the first piece of DuPont™ FlexWrap™ NF on each side by 2". Install along the top of the beam and down each side, overlapping the lower piece of DuPont™ FlexWrap™ NF by 2" using the method above.

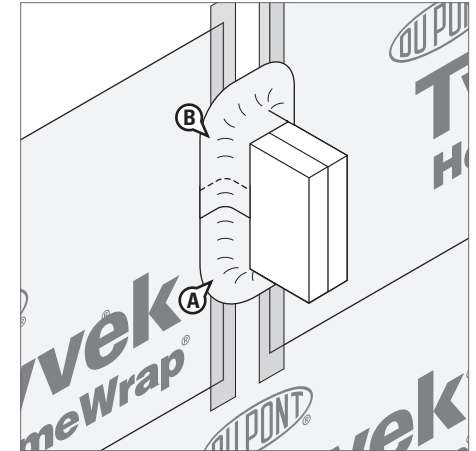

STEP 4

- A. Install the top course of the DuPont™ Tyvek® WRB, overlapping the DuPont™ Tyvek® WRB below with 1" gap above the beam. Tape all vertical seams with DuPont™ Tyvek® Tape. **NOTE:** For air barrier installations, seal all vertical and horizontal seams.

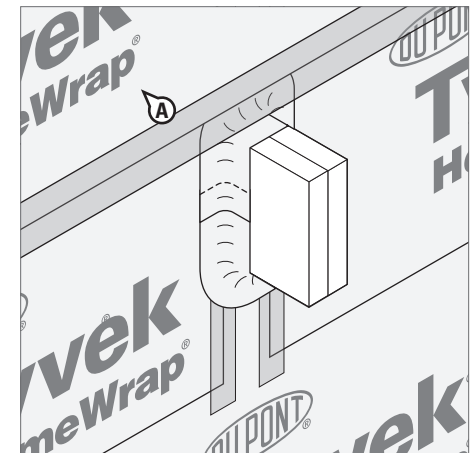

DuPont™ Tyvek® Water-Resistive and Air Barriers Installation Guidelines for Open Stud Construction

Handling Tears and Holes

During the course of installing the DuPont™ Tyvek® WRB, minor tears may occur. Be sure to tape all tears. Tears can easily be covered with DuPont™ Tyvek® Tape (2" or 3") or DuPont™ Self-Adhered Flashing products.

Larger holes (greater than 1") may require cutting a piece of DuPont™ Tyvek® WRB to cover the hole, maintaining proper shingling.

Cut a slit 2" above the hole and extending a minimum of 2" on each side of the hole. Measure and cut a piece of DuPont™ Tyvek® WRB to fit into the slit and cover the hole. Tuck the cut piece of DuPont™ Tyvek® WRB into the slit. Tape along the perimeter by starting at the bottom of the patch, shingling upper tape over bottom tape.

Tears

STEP 1

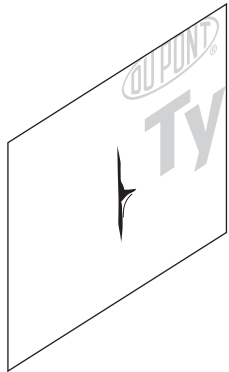

STEP 2

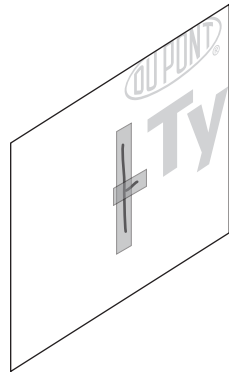

Holes

STEP 1

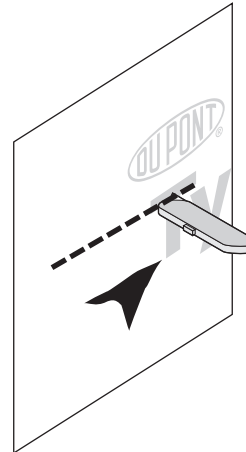

STEP 2

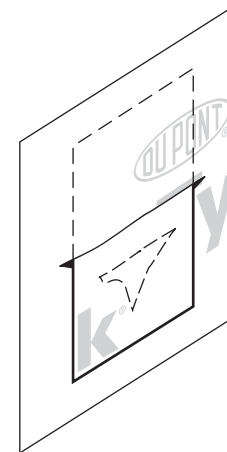

STEP 3

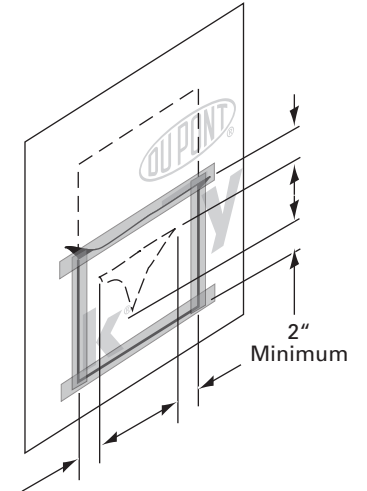

DuPont Flashing Systems Integration

If windows and doors have not been installed, reference the *DuPont™ Self-Adhered Flashing Systems Installation Guidelines, Installation Instructions for Windows and Doors AFTER Water-Resistive Barrier (WRB) is Installed* to prepare the rough opening.

If windows and doors will be installed before the WRB, then follow these last 4 integration steps to tie the DuPont™ Tyvek® WRB into the flashing.

STEP 1

A. After installing the flashing and the window or door following the steps detailed in the applicable *DuPont™ Self-Adhered Flashing Systems Installation Guidelines, Installation Instructions for Windows and Doors BEFORE Water-Resistive Barrier (WRB) is Installed*, install the DuPont™ Tyvek® WRB. Do not install fasteners within 4" of the window frame at jambs and head, and within 12" of the window frame at sill or location of apron.

B. Mark a perimeter on the DuPont™ Tyvek® WRB around the rough opening a minimum of 1" from the jambs and head of the window frame, and 6" below the sill of the window frame.

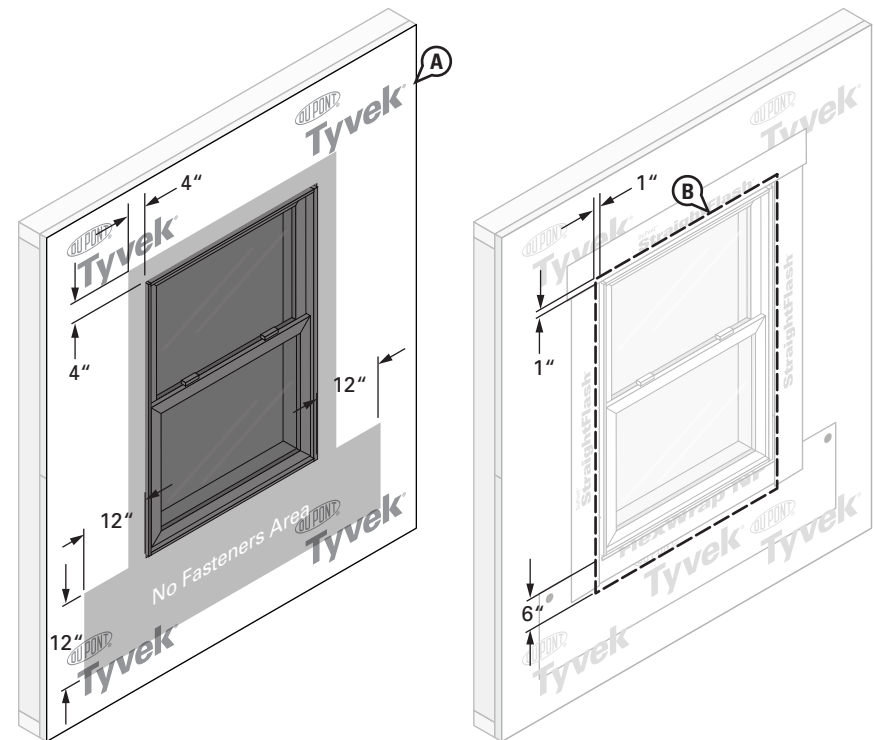

DuPont™ Tyvek® Water-Resistive and Air Barriers Installation Guidelines for Open Stud Construction

STEP 3

A. Cut the DuPont™ Tyvek® WRB along perimeter marking to expose window. Do not cut through the DuPont™ Self-Adhered Flashing products or DuPont™ Tyvek® WRB apron underneath.

ALTERNATE STEP A: If apron extends far enough below the sill rough opening to overlap the sill plate, base of wall flashing, or the DuPont™ Tyvek® WRB below, the DuPont™ Tyvek® WRB can be cut along jambs and head only to overlap apron.

B. Create horizontal slits in the DuPont™ Tyvek® WRB at each lower corner of the perimeter cut that extend a minimum of 2" beyond DuPont™ Tyvek® WRB apron.

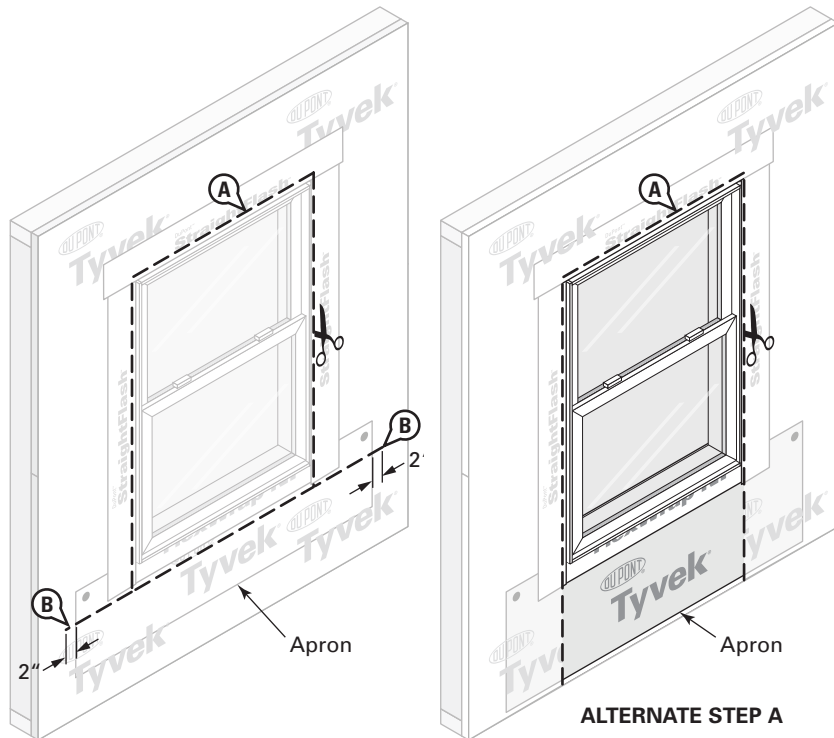

STEP 4

- A. Bring the bottom portion of the DuPont™ Tyvek® WRB apron through the sill perimeter cut and horizontal slits so it laps over the top layer of DuPont™ Tyvek® WRB.
- B. Working from bottom to top, install DuPont™ Tyvek® Tape to secure horizontal and vertical seams of DuPont™ Tyvek® WRB apron.
- C. Install DuPont™ Tyvek® Tape along jambs and head to seal DuPont™ Tyvek® WRB around window.

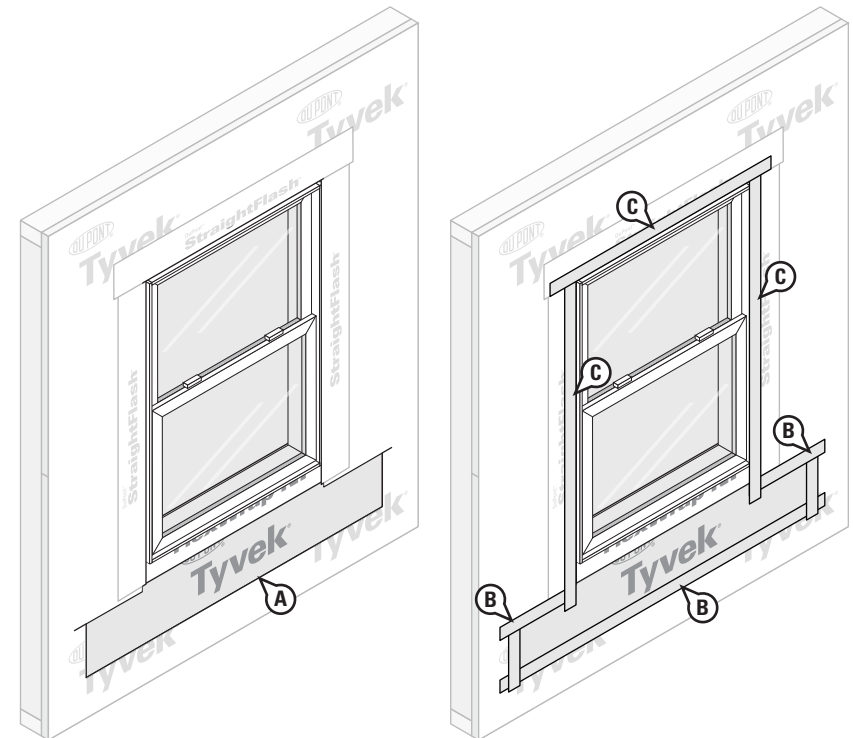

Facade Considerations

Water-resistive barrier performance is dependent upon the ability of the facade to drain. The following must be considered for specific facades.

Stucco and Direct-Applied Stone

When stucco is installed over wood-based sheathing, the 2015 International Building Code (Section 2510.6) requires a water-resistive vapor-permeable barrier with a performance at least equivalent to two layers of water resistive barrier complying with ASTM E 2556, Type I, or a water resistive barrier which is separated from the stucco by an intervening, substantially nonwater-absorbing layer or drainage space. When stucco is installed over wood-based sheathing, the 2015 International Residential Code (Section R703.7.3) requires a water-resistive vapor-permeable barrier with a performance at least equivalent to two layers of Grade D paper or a water-resistive barrier which is separated from the stucco by an intervening, substantially nonwater-absorbing layer or designed drainage space. The individual layers shall be installed independently such that each layer provides a separate continuous plane and any flashing intended to drain to the water-resistive barrier is directed between the layers. DuPont™ Tyvek® WRBs used behind stucco should be separated from the stucco by a second layer of DuPont™ Tyvek® WRB, a layer of Grade D building paper, felt, rigid foam board or the paper backing of paper-backed lath. The first layer (directly over sheathing or studs) serves as the wall system's water-resistive barrier and is integrated with window and door flashings, the weep screed at the bottom of the wall and any through wall flashings or expansion joints. Lath shall be installed over the intervening layer in accordance with ASTM C1063-03 Standard Specification for Installation of Lathing and Furring to Receive Interior and Exterior Portland Cement-Based Plaster and applicable codes. Rigid foam board, when installed over DuPont™ Tyvek® WRB as an intervening layer, will provide enhanced structural support to the DuPont™ Tyvek® WRB and may reduce the required number of fasteners used for the attachment of the DuPont™ Tyvek® WRB if installed as soon as practically possible. DuPont™ Tyvek® StuccoWrap®, DrainWrap™ or CommercialWrap® D is recommended for this application.

Brick

The 2015 International Residential Code (Section R703.8.4) requires a nominal 1 inch airspace separating the brick from the water-resistive barrier (WRB). The Brick Industry Association recommends a 1 inch air-space in front of wood stud construction and a 2 inch air-space in front of steel stud construction. Consistent with these requirements and recommendations, DuPont™ Tyvek® WRBs shall be separated from the brick veneer by a nominal 1 inch air-space. Window and door flashing, and through-wall flashing shall be integrated with the DuPont™ Tyvek® WRB layer ensuring proper shingling. For maximum moisture management and drying of the wall system the airspace in front of the DuPont™

Tyvek® WRB shall be vented to the exterior at the top and bottom of the wall. Some types of brick ties will act as additional fasteners for DuPont™ Tyvek® WRBs, and, if installed as soon as practically possible after the DuPont™ Tyvek® WRB, may reduce the required number of fasteners used for the initial attachment of the DuPont™ Tyvek® WRB.

Stone Veneer

The 2015 International Building Code (Section 1405.10) requires two layers of water resistive barrier (WRB) behind stone veneers over wood frame construction. When used behind stone veneer, DuPont™ Tyvek® WRBs shall be installed in a similar manner as they are installed behind stucco. DuPont™ Tyvek® WRBs should be separated from the stone and mortar by a second layer of DuPont™ Tyvek® WRB, a layer of grade D building paper, felt, rigid foam board or the paper backing of paper-backed lath. The first layer (directly over sheathing or studs) serves as the wall system's air and water barrier and shall be integrated with window and door flashings, the weep screed at the bottom of the wall and any through wall flashing or expansion joints. Lath shall be installed over the intervening layer (second layer) in accordance with ASTM C1063-03 Standard Specification for Installation of Lathing and Furring to Receive Interior and Exterior Portland Cement-Based Plaster and applicable codes. When rigid foam board is used as the second layer, it is installed over the DuPont™ Tyvek® WRB. DuPont™ Tyvek® StuccoWrap®, DrainWrap® or CommercialWrap® D is recommended for this application.

Wood Siding

The DuPont™ Tyvek® WRB and wood siding shall be installed according to manufacturer's instructions, industry standards and applicable codes. As recommended by the Western Red Cedar Lumber Association and U. S. Forest Product Laboratory, wood siding should be primed on all six sides before installation. Foam sheathing panels often have low vapor permeability, and therefore can cause moisture to accumulate on the back of siding and cause staining, buckling and damage to finish coats. As a result, the Western Red Cedar Lumber Association and other wood siding manufacturers recommend that furring strips are used to create an air space between foam sheathing and siding. Other recommendations that should be followed to minimize potential problems are:

- Use thicker siding patterns in widths of 8 inches or less. Thick, narrow siding is more stable than thinner, wider patterns and better able to resist dimensional changes.
- Use kiln-dried siding over rigid foam sheathing.
- Proper pre-finishing is essential.
- Use light color finish coats to maximize heat reflection and reduce dimensional movement.
- DuPont™ Tyvek® StuccoWrap®, DrainWrap™ or CommercialWrap® D applied over the foam sheathing is recommended for this application.

DuPont™ Tyvek® Water-Resistive and Air Barriers Installation Guidelines for Open Stud Construction

In high exposure installations, enhanced drainage and water management may be provided by using DuPont™ Tyvek® StuccoWrap®, DrainWrap™ or CommercialWrap® D, by installing a drainage mesh over the water-resistive barrier, or by creating rainscreen cladding with a larger air space behind the siding using furring strips. If furring is installed over the DuPont™ Tyvek® WRB to create a rainscreen, the primary fastener spacing can exceed 18”.

Fiber Cement Siding

DuPont™ Tyvek® WRBs and fiber cement siding shall be installed according to manufacturer’s instructions and industry standards. In high exposure installations, enhanced drainage and water management may be provided by using DuPont™ Tyvek® StuccoWrap®, DrainWrap™ or CommercialWrap® D, by installing a drainage mesh over the water-resistive barrier, or by creating rainscreen cladding with a larger air space behind the siding using furring strips. If furring is installed over the DuPont™ Tyvek® WRB to create a rainscreen, the primary fastener spacing can exceed 18”. In high wind areas at gable end walls, FEMA recommends fiber cement siding be installed over wood sheathing rather than over plastic foam sheathing. DuPont™ Tyvek® WRBs and fiber cement siding shall be installed according to manufacturer’s instructions, industry standards and applicable codes.

Vinyl Siding

Vinyl Siding is installed directly over DuPont™ Tyvek® WRBs. Vinyl siding shall be installed in accordance with manufacturer’s instructions, industry standards and applicable codes, including ASTM D4756-15 Standard Practice for Installation of Rigid Poly(Vinyl Chloride) (PVC) Siding and Soffit. In high wind areas at gable end walls, FEMA recommends vinyl siding be installed over wood sheathing rather than over plastic foam sheathing.

EIFS

DuPont™ Tyvek® WRBs and EIFS cladding shall be installed according to manufacturer’s instructions and industry standards. In order to promote drainage, it is recommended that DuPont™ Tyvek® StuccoWrap®, DrainWrap® or CommercialWrap® D be installed behind the exterior insulation. Window and door flashing, and through wall flashing shall be integrated with the DuPont™ Tyvek® WRB layer ensuring proper shingling. The successful installation and performance of EIFS cladding is dependent upon the proper design and construction of the adjacent materials and systems of the structure.

Exterior Insulation

DuPont™ Tyvek® WRBs and exterior insulation shall be installed according to the manufacturer’s instructions and industry standards. DuPont™ Tyvek® WRBs can be installed either over the rigid exterior insulation or underneath between the sheathing and the exterior insulation. In order to promote drainage, it is recommended that DuPont™ Tyvek® StuccoWrap®, DrainWrap® or CommercialWrap® D be used when

installing the DuPont™ Tyvek® WRB layer between the sheathing and exterior insulation. Window flashing, door flashing, and through wall flashing shall be integrated with the DuPont™ Tyvek® WRB layer ensuring proper shingling. The successful installation and performance of exterior insulation is dependent upon the proper design and construction of adjacent materials and systems of the structure.

NOTE: DuPont™ RainVent™ Battens can be used to improve the ventilation and draining space behind wood, stucco or stone masonry, vinyl, and fiber cement cladding types.

Temporary Fastening

Selection and use of temporary fastening methods is an option dependent on building schedule, cladding options, and local building practices. Temporary fasteners should not be relied upon to permanently attach DuPont™ Tyvek® WRBs due to the limited holding power of these fastening methods. If temporary fasteners are used, permanent fastening should be applied as soon as practically possible in order to maintain the integrity and performance of the DuPont™ Tyvek® WRB. Permanent fasteners include cladding fasteners such as brick ties, lath fasteners for traditional stucco, exterior foam board fasteners, or siding installed with nails.

Temporary fastening methods:

- DuPont fasteners or equivalent alternate fasteners at a reduced schedule of 24” to 48”.
- DuPont™ Adhesive/Primer or other recommended adhesive applied in vertical strips at 24” to 36” spacing or along every other stud line. Vertical strips may be applied to the outer face of the sheathing or directly to the studs for open stud construction. When using adhesives, care must be taken to avoid excessive surface coverage as this may impact the vapor permeability of the DuPont™ Tyvek® WRB in that area.
- If staples without caps are used to temporarily fasten DuPont™ Tyvek® WRBs to OSB, plywood, or exterior gypsum sheathing, the fastening schedule must not exceed 4 per square yard. If installing as an air barrier, each staple must be covered with DuPont™ Tyvek® Tape. Covering the staples underneath a taped air and water barrier seam is also acceptable if installing DuPont™ Tyvek® WRB as an air barrier. Staples should not be used with fiberboard or foam sheathing.

NOTE: These Temporary Fastening Guidelines are subject to change based on new technology or testing information and may be superseded at any time. It is always important to follow the latest guidelines which may be found on www.Weatherization.Tyvek.com. For additional guidance, please consult your local DuPont™ Tyvek® Specialist.

Key Installation Requirements for DuPont™ Tyvek® WRBs

Continuity

It is important to maintain the continuity of the WRB throughout the building envelope. The entire wall surface shall be wrapped, including unconditioned spaces. Special attention should be given to ensure a proper 6" overlap at all terminations, seams, penetrations, and transitions to maintain a continuous downward drainage plane and WRB. Installing the DuPont™ Tyvek® WRB as an air barrier is the preferred installation method. However, skip-taping terminations and untaped horizontal seams is allowed when the DuPont™ Tyvek® WRB is being installed as a water-resistive barrier only for buildings less than 5 Stories and low-rise multi-family buildings less than 6 Stories with design requirements that don't exceed ASTM E1677, 65 mph equivalent structural load and 15 mph equivalent wind-driven rain water infiltration. All vertical seams must be taped for both air barrier and water-resistive barrier installations.

Penetrations

Seal DuPont™ Tyvek® WRBs around all penetrations (electrical, HVAC and plumbing, etc.) with the appropriate DuPont™ Flashing Systems product, DuPont™ Tyvek® Tape, DuPont™ Residential Sealant or recommended sealant. Products that have flanges should be integrated into the DuPont™ Tyvek® WRB. DuPont™ StraightFlash™, DuPont™ Flashing Tape or DuPont recommended alternate patches should be applied behind fastening plates (brick tie base plates, metal fastening clips, metal channels, etc.) when building envelope design requirements exceed ASTM E1677, 65 mph equivalent structural load and 15 mph equivalent wind-driven rain water infiltration resistance. Please contact 1-800-44-Tyvek for recommended sealants and recommended alternate patches behind fastening plates.

Fasteners

Use DuPont or equivalent fasteners per the fastening schedule included in this installation guideline. Examples of recommended fasteners include:

- DuPont™ Tyvek® Wrap Cap nails (for wood frame construction)
- DuPont™ Tyvek® Wrap Cap Staples or other cap staples for Stinger™ Cap Stapler (for wood frame construction)
- Other manufacturers' equivalent 1" plastic cap screws, nails, and staples (for wood frame construction).
- DuPont™ Tyvek® Wrap Cap or other manufacturers' equivalent 2" plastic cap screws (for steel or wood frame construction)
- 1-1/4" metal gasketed washers with screws (for steel frame construction)
- 2" metal gasketed washers with screws (for steel frame construction)
- Tapcon® fasteners with 2" plastic caps (for masonry construction)

If temporary fasteners are used, permanent fastening must be installed as soon as practically possible. In this case, permanent fasteners include cladding fasteners such as brick ties, lath fasteners for traditional stucco, exterior foam board fasteners, or siding installed with nails. Cladding shall be installed according to applicable building codes and industry standards.

Proper Overlap for Water Management

- A. Lap all components from bottom of the wall to the top of the wall
- B. Treat the walls of the building just like a roof

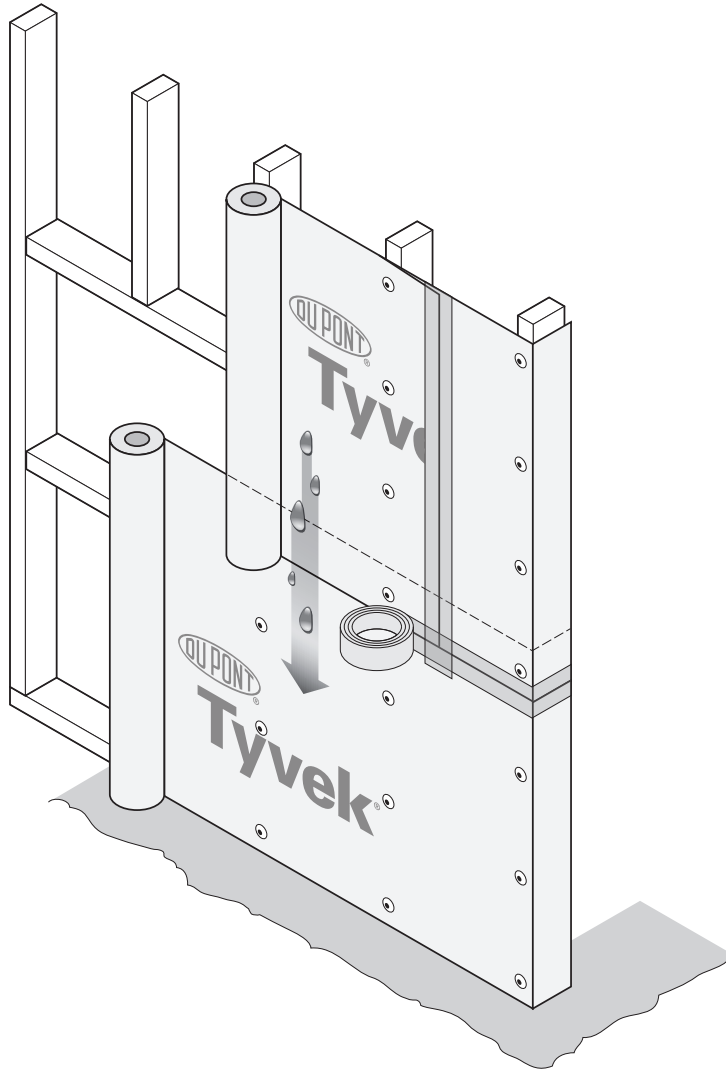

NOTE: In order to make a claim under the DuPont 10-Year Limited Product and Labor Warranty on DuPont Weatherization Products, you must have met all of the terms and conditions of the warranty, including use of the applicable DuPont Installation Guidelines. In the event that a specific detail or installation technique is not covered in the DuPont Installation Guidelines at the time you are building, then the Key Installation Requirements outlined in this document must have been followed in order to make a claim under the warranty. Compliance prior, during and post construction with the Key Installation Requirements are at the sole discretion of DuPont. Please contact DuPont or a DuPont™ Tyvek® Specialist if you have any questions in connection with any DuPont Installation Guideline.

DuPont™ Tyvek® Water-Resistive and Air Barriers Installation Guidelines for Open Stud Construction

Technical Specifications

DuPont™ Tyvek® WRBs used in construction products are made from 100% flash spunbonded high density polyethylene fibers which have been bonded together by heat and pressure, without binders or fillers, into a tough, durable sheet structure. Additives have been incorporated into the polyethylene to provide ultraviolet light resistance. DuPont requires that DuPont™ Tyvek® CommercialWrap® and CommercialWrap® D WRB's be covered within 9 months (270 days) of installation and that all other DuPont WRB's be covered within 4 months (120 days) of installation.

DuPont™ Self-Adhered Flashing products are made from a synthetic rubber adhesive and a laminate of polyethylene film, polypropylene film, elastic fiber, synthetic rubber adhesive, polyurethane adhesive, and a top sheet of flash spunbonded high density polyethylene fibers or polypropylene film. Additives have been incorporated into these materials to provide ultraviolet light resistance. DuPont requires that DuPont™ FlexWrap™ EZ, FlexWrap™ NF, StraightFlash™ and StraightFlash™ VF be covered within nine months (270 days) of installation. DuPont requires that DuPont™ Flashing Tape be covered within four months (120 days) of installation.

Warning

DuPont™ Tyvek® WRBs are slippery and should not be used in any application where they will be walked on. In addition, because they are slippery, DuPont recommends using kickjacks, scaffolding, or lifts for exterior work above the first floor. If ladders must be used, extra caution must be taken to use them safely by following the requirements set forth in ANSI Standards 14.1, 14.2, and 14.5 for ladders made of wood, aluminum, and fiberglass, respectively. DuPont™ Tyvek® WRBs are combustible and should be protected from flames and other high heat sources. DuPont™ Tyvek® WRBs will melt at 275°F (135°C) and if the temperature of DuPont™ Tyvek® WRBs reach 750°F (400°C), they will burn and the fire may spread and fall away from the point of ignition.

DuPont™ DuPont™ Self-Adhered Flashing products and their release paper are slippery and should not be walked on. Remove release paper from work area immediately. DuPont™ Self-Adhered Flashing products will melt at temperatures greater than 250°F (121°C). DuPont™ Self-Adhered Flashing products are combustible and should be protected from flames and other high heat sources. DuPont™ Self-Adhered Flashing products will not support combustion if the heat source is removed. However, if burning occurs, ignited droplets may fall away from the point of ignition.

DuPont™ Residential Sealant is irritating to skin, eyes, and respiratory tract. For proper usage, follow directions stated on the product label. For health information, refer to the Material Safety Data Sheet or call Chemtrec at 1-800-424-9300.

Note

When installed in conjunction with other building materials, DuPont™ Self-Adhered Flashing products must be properly shingled with these materials such that water is diverted to the exterior of the wall system. DuPont™ Tyvek® WRBs are air and water barriers and not the primary water barrier. The outer facade is the primary barrier. You must follow facade manufacturer's installation and maintenance requirements for all facade systems in order to maintain water holdout properties and ensure performance of DuPont™ Tyvek® WRBs. Use of additives, coatings or cleansers on or in the facade system may impact the performance of DuPont™ Tyvek® WRBs. DuPont products are to be used as outlined in this installation guideline. DuPont™ Self-Adhered Flashing products should only be used to seal penetrations and flash openings in houses or buildings. DuPont™ Self-Adhered Flashing products are not to be used in roofing applications. For superior protection against bulk water penetration, DuPont suggests a system combining a quality exterior facade, a good secondary WRB and exterior sheathing, high quality windows and doors, and appropriate flashing materials paying attention to proper installation of each component. In a system where no exterior sheathing is used and the DuPont™ Tyvek® WRB is installed directly over the wall studs, exterior facade materials should be selected to ensure maximum protection against water intrusion. Careful workmanship and proper installation of each component is very important.

DuPont believes this information to be reliable and accurate. This information may be subject to revision as additional experience and knowledge is gained. It is the user's responsibility to determine the proper construction materials needed on each project.

This information is not intended to be used by others for advertising, promotion or other publication for commercial purposes.

For more information about DuPont™ Tyvek® Building Envelope Solutions, please call 1-800-44-Tyvek or visit us at www.Weatherization.Tyvek.com



Tyvek.

The Tyvek logo graphic features a horizontal bar composed of several segments in shades of blue and grey, positioned above the word "Tyvek." in a bold, blue, sans-serif font.